

STRUCTURAL NOTES:

- THIS NON POROUS SYSTEM HAS BEEN VERIFIED FOR COMPLIANCE IN ACCORDANCE WITH THE 2010 EDITION OF THE FLORIDA BUILDING CODE (FBC). THIS SYSTEM SHALL NOT BE INSTALLED IN THE HIGH VELOCITY HURRICANE ZONE (HMA-ONE/ BROWARD COUNTIES), NOR WIND ZONE 4 (FBC SECTION 1609.1.2.4) NOR ESSENTIAL FACILITIES IN WIND ZONES 1, 2, 3 OR 4. THE ADEQUACY FOR IMPACT, DEFLECTION AND FATIGUE RESISTANCE HAS BEEN VERIFIED IN ACCORDANCE WITH SECTION 1626 OF THE ABOVE REFERENCED CODE, AND AS PER TAB 201, TAB 202 AND TAB 203 PROTOCOLS AND ASTM E330-02, ASTM E1996-05 AND ASTM E1996-06. SEE LIST OF REPORTS ON SHEET 1/2.
- DESIGN PRESSURE REQUIREMENTS OF A SPECIFIC SITE SHALL BE DETERMINED BY OTHERS IN COMPLIANCE WITH SECTION 1609 OF THE FBC FOR A BASIC WIND SPEED (ALLOWABLE STRESS DESIGN) AS REQUIRED BY THE JURISDICTION WHERE THE SYSTEM WILL BE INSTALLED. ULTIMATE DESIGN LOADS (UD) DETERMINED BY ASCE 7-10 SHALL BE REDUCED TO ALLOWABLE STRESS DESIGN LOADS (ASD) BY MULTIPLYING THE UD BY 0.6 TO COMPARE THEM TO THE ASD PRESSURE RATINGS SHOWN ON SHEET 1 AND 2. USE OF DIRECTIONALITY FACTOR K_d=0.85 IS ALLOWED.
- IMPACT AND FATIGUE RESISTANCE HAS BEEN DETERMINED IN ACCORDANCE WITH THE FBC SECTION 1626 LARGE MISSILE AND 1609.1.2 MISSILE TYPE "D" AS LISTED HEREIN.
- NO 33-1/2" INCREASE IN ALLOWABLE STRESS INCREASE HAS BEEN USED IN THE DESIGN OF THIS PRODUCT.
- THIS PRODUCT EVALUATION DOCUMENT (PED) DETAILED HEREIN IS GENERIC AND DOES NOT PROVIDE INFORMATION FOR A SPECIFIC SITE. IF SITE CONDITIONS DEVIATE FROM THE CONDITIONS DETAILED HEREIN, A LICENSED ENGINEER OR REGISTERED ARCHITECT SHALL PREPARE SITE SPECIFIC DOCUMENTS TO BE USED IN CONJUNCTION WITH THIS DOCUMENT.
- THE CONTRACTOR AND / OR PERMIT HOLDER IS TO BE RESPONSIBLE FOR THE SELECTION, PURCHASE AND INSTALLATION OF THIS SYSTEM, INCLUDING VERIFYING THE ADEQUACY OF THE EXISTING STRUCTURE TO WITHSTAND THE NEW SUPERIMPOSED LOADS SHOWN BELOW AND THE SOUNDNESS OF THE STRUCTURE WHERE THE SYSTEM IS TO BE ATTACHED TO INSURE PROPER ANCHORAGE.
- SITE SPECIFIC PROJECTS SHALL BE PREPARED BY A FLORIDA LICENSED ENGINEER OR ARCHITECT WHO WILL BECOME THE ENGINEER OF RECORD (EOR) FOR THE PROJECT AND WHO WILL BE RESPONSIBLE FOR THE PROPER USE OF THE PED ENGINEER OF RECORD, ACTING AS A DELEGATED ENGINEER TO THE PED ENGINEER SHALL SUBMIT TO THIS ENGINEER THE SITE SPECIFIC DRAWINGS FOR REVIEW.
- THIS SYSTEM SHALL BEAR THE DATE AND ORIGINAL SEAL OF THE PROFESSIONAL ENGINEER OF RECORD THAT PREPARED IT.
- THIS SYSTEM MAY ALSO BE INSTALLED HORIZONTALLY FOLLOWING INSTALLATION DETAILS SHOWN HEREIN.
- THIS WIND ABATEMENT SYSTEM IS INTENDED FOR USE ONLY DURING HURRICANE OR OTHER TROPICAL STORM WARNINGS. SEASONAL OR PERMANENT INSTALLATION OR STORAGE OF THIS WIND ABATEMENT SYSTEM IN AREAS OF PROLONGED EXPOSURE TO DIRECT SUNLIGHT OR OTHER WEATHERING CONDITIONS MAY CAUSE MATERIAL DEGRADATION OR OTHERWISE IMPAIR THEIR ADEQUACY AS AN IMPACT RESISTANT SYSTEM.
- LIMITATIONS OF USE:
PER FBC 2010 NO MINIMUM SEPARATION FROM GLASS IS REQUIRED.
THE MAXIMUM SIZE SHALL BE 60 PSF MAX. PRESSURE @216 INCHES MAXIMUM SPAN. SEE TABLES ON SHEET 1/2 AND 2/2.
- RESERVED.
- ALL SCREENS TO BE STAINLESS STEEL 304 OR 316 SERIES OR CORROSION RESISTANT COATED CARBON STEEL WITH A 50 KSI YIELD STRENGTH AND A 90 KSI TENSILE STRENGTH.
- ALL BOLTS TO BE ASTM A307, GALVANIZED OR 304 SERIES STAINLESS STEEL WITH A MINIMUM 36 KSI YIELD STRENGTH.
- ANCHORS TO STRUCTURE (WALL / FLOOR / CEILING / SYSTEM) SHALL BE INSTALLED PER MANUFACTURERS' RECOMMENDATIONS AND AS FOLLOWS:
 - CONCRETE BLOCK MASONRY (ASTM C-90)
 TYPICAL ANCHORS (TYP BULDED) OR PANELMATE MALE & FEMALE FASTENERS (ELOD TETRON) - 1/4" N. DIA.
 I. MINIMUM EMBEDMENT INTO HOLLOW CONCRETE BLOCK MASONRY FOR TYPICAL ANCHORS AND ELOD PANELMATES IS 1 1/4".
 NO EMBEDMENT INTO STUCCO SHALL BE PERMITTED. SCREENS TO BE 1/4"-20 X 1 3/4" FOR STUCCO, 1 1/4" WITH NO STUCCO.
 II. PANELS, BRICKS OR OTHER PRE-CAST PRODUCTS LOCATED ON THE EXISTING STRUCTURE WALL OR FLOOR SHALL HAVE ANCHORS OF SUFFICIENT LENGTH TO PROPERLY ATTACH TO THE PRIMARY STRUCTURE BEHIND IT.
 III. MINIMUM EDGE DISTANCE = 3.0"
 - WOOD (Nominal 2x4(min) Southern Pine Sg=0.55 OR GREATER)
 TYPICAL ANCHORS (TYP BULDED) OR PANELMATE MALE & FEMALE FASTENERS (ELOD TETRON) - 1/4" N. DIA.
 I. MINIMUM EDGE DISTANCE = CENTER OF 2" NOMINAL LUMBER (APPROX. 3/4"). MINIMUM EMBEDMENT = 1-1/2"
 - MAXIMUM DESIGN PRESSURE VERSUS PANEL SPAN SHOWN ON SHEET 2/2
- SCREEN PANEL'S MANUFACTURER LABEL SHALL BE PLACED ON A READY AND VISIBLE LOCATION ON THE PANEL. ONE LABEL SHALL BE PLACED FOR EVERY OPENING. LABEL SHALL READ AS FOLLOWS:
 HURRICANE FABRIC LLC
 PO BOX 50153, CLAYTON, MO 63105
 FLORIDA PRODUCT APPROVAL NUMBER: F-200X. OPENING NO.: XX
 THIS DOCUMENT IN ITS ENTIRETY WILL BE CONSIDERED INVALID IF IT IS ALTERED BY ANY MEANS.

FASTENER SPACING OF A SINGLE UNIT SCREEN FOR ANY LENGTH ATTACHED WITH 1/4" ELOD PANELMATE PRO. MALE & FEMALE (INCHES)

SCREEN SPAN	FILLED CMU (1900 PSI)			CONCRETE (4000 PSI)			HOLLOW CMU			TIMBER		
	60	40	30	60	40	30	60	40	30	60	40	30
4'-0"	15	18	18	18	18	18	11	13	15	18	10	11
6'-0"	11	12	15	18	12	14	8	9	10	13	7	8
8'-0"	7	8	10	12	8	9	5	6	7	9	5	6
10'-0"	6	7	8	10	7	8	4	5	6	7	4	5
12'-0"	5	6	7	9	6	7	4	5	6	7	4	5
14'-0"	4	5	6	7	5	6	4	5	6	7	4	5
16'-0"	3	4	5	6	4	5	4	5	6	7	4	5
18'-0"	2	3	4	5	3	4	3	4	5	6	3	4

FASTENER SPACING OF A SINGLE UNIT SCREEN FOR ANY LENGTH ATTACHED WITH 3/8" DROP-IN ANCHOR WITH SIDEWALK BOLT (INCHES)

SCREEN SPAN	FILLED CMU (1900 PSI)			CONCRETE (4000 PSI)			HOLLOW CMU			TIMBER		
	60	40	30	60	40	30	60	40	30	60	40	30
4'-0"	18	18	18	18	18	18	18	18	18	18	13	15
6'-0"	14	16	18	18	18	18	12	14	17	18	9	11
8'-0"	12	14	16	18	18	18	10	12	14	17	8	10
10'-0"	10	12	14	16	18	18	9	10	12	15	7	9
12'-0"	9	10	12	14	16	18	8	9	10	12	6	8
14'-0"	8	9	10	12	14	16	7	8	9	10	5	7
16'-0"	7	8	9	10	11	13	6	7	8	9	4	6
18'-0"	6	7	8	9	10	12	5	6	7	8	3	5

RETENTION CLIP END CONNECTOR:

RHOVA ENGINEERING PLASTICS - POLYURETHANE 66

FABRIC SPECIFICATION:

FIBER CONTENT: TEXTILE FABRIC

CONSTRUCTION: 20 X 20 WEAVE

FRESH RESIN COATED

WEIGHT (ASTM D-3776): 9.0 - OZ/SQUARE YARD

TENSILE STRENGTH (9988 METHOD, ASTM D -4632): WARP - 570 lbs., WEFT - 570 lbs.

BURST STRENGTH (ASTM D - 3785): 1,000 PSI

ABRASION RESISTANCE (ASTM D -4989) 95% STRENGTH REMAINED

SEWING:

ONLY SEWING IS AT STITCH

EDGES:

NO SEWING AT EDGES

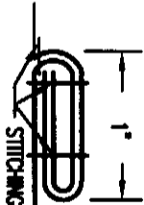

SPLICE DETAIL

EVALUATION BASED ON:
FENESTRATION TESTING LABORATORY, INC

LAB NO.: 6418 DATED 12/7/2010

ASTM E330-02 - UNIFORM STATIC LOADS
ASTM E1996-05 & ASTM E1996-06 - LARGE MISSILE TYPE
"D" IMPACT RESISTANCE & CYCLIC LOADING
PERFORMANCE

LAB NO.: 5804 DATED 01/13/2009

TAB 202 - UNIFORM STATIC LOADS
TAB 201, TAB 202 - LARGE MISSILE IMPACT RESISTANCE &
CYCLIC LOADING PERFORMANCE

LIST OF REPORTS

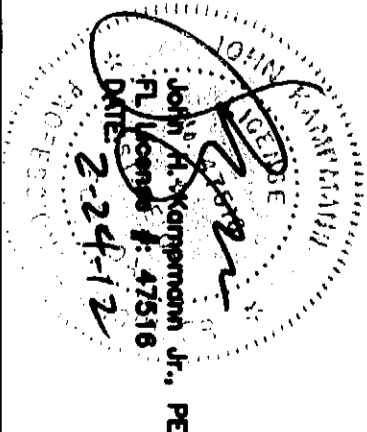

5 #6782

WWW.MEANENGINEERS.COM



8888 Linden Dr
Tampa, Florida 34613
(813) 922-3854 FAX 813-922-8072

REV.	DESCRIPTION
1	xx/xx/xx-RESERVED

Project Name:
HURRICANE FABRIC LLC
PO BOX 50153
CLAYTON, MO 63105
PHONE: (238)988-0088
WWW.HURRICANEFABRIC.COM

Description:
ASTRO GUARD
Wind Abatement System

Project No.: JK
Drawing No.: F-12-0226
Scale: NTS
Date: 02/24/12

1/2

2010 FBC (NON-HIGH VELOCITY HURRICANE ZONE)

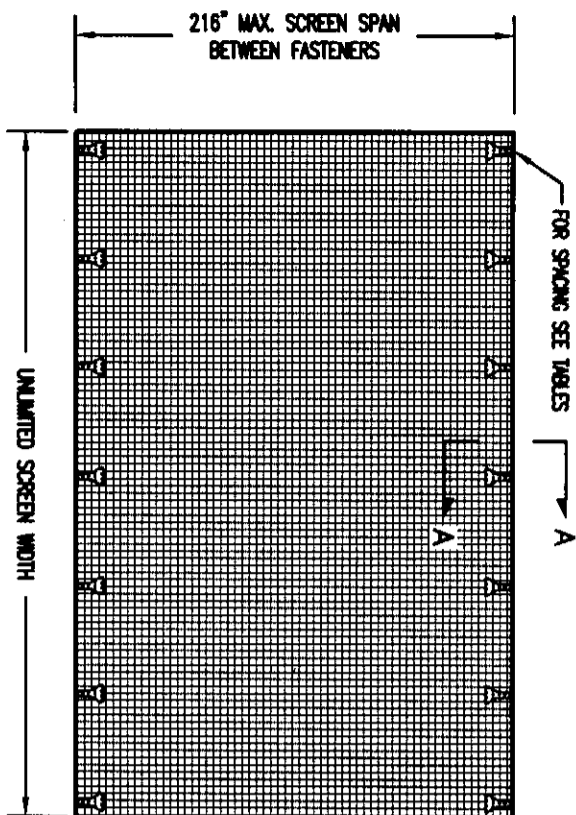

TYPICAL TWO-SIDED INSTALLATION
VERTICAL OR HORIZONTAL INSTALLATION - N.T.S.

NOTE:
PANELS CAN BE ATTACHED ON THREE OR FOUR SIDES.
FOR FOUR SIDE ATTACHMENT THE SPAN IS IN THE SHORT
DIMENSION BETWEEN FASTENERS

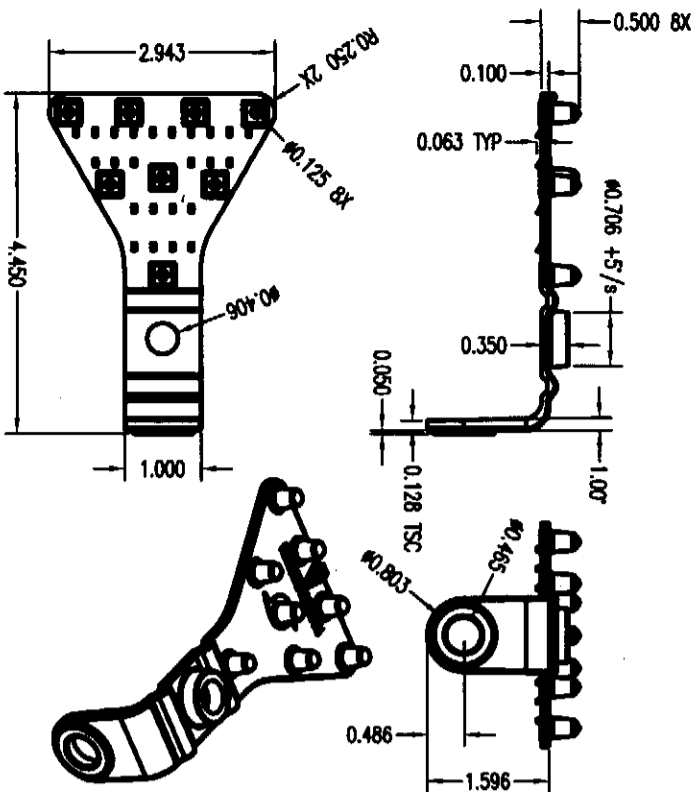

BOTTOM MOUNTING CLIP DETAILS
INSIDE OR OUTSIDE MOUNT INSTALLATION - N.T.S.

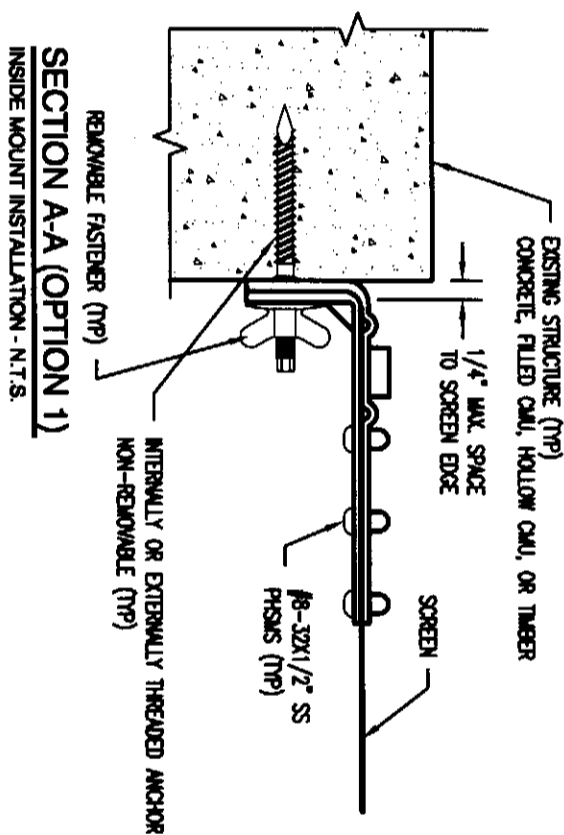

SECTION A-A (OPTION 1)
INSIDE MOUNT INSTALLATION - N.T.S.

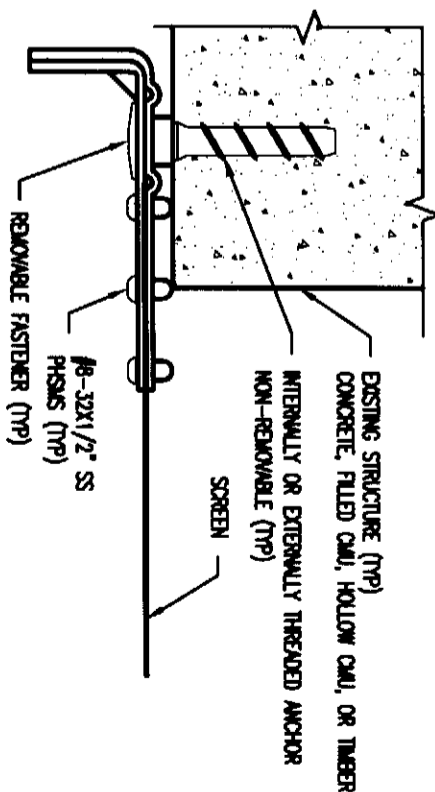

SECTION A-A (OPTION 2)
OUTSIDE MOUNT INSTALLATION - N.T.S.

LOADS ON EXISTING STRUCTURE FROM SCREEN SYSTEM
TX = PARALLEL LOADS (PLF)

SPAN (INCHES)	PRESSURE (PSF)					
	60	55	50	45	40	30
216	1134	1070	1004	936	866	792
192	1020	962	903	842	778	712
168	905	854	801	747	690	631
144	744	702	659	614	568	519
120	651	615	577	538	497	455
96	553	521	489	456	422	386
72	353	333	312	291	269	246
48	254	240	225	210	194	178

LOADS ON EXISTING STRUCTURE FROM SCREEN SYSTEM
TY = PERPENDICULAR LOADS (PLF)

SPAN (INCHES)	PRESSURE (PSF)					
	60	55	50	45	40	30
216	540	495	450	405	360	315
192	480	440	400	360	320	280
168	420	385	350	315	280	245
144	360	330	300	270	240	210
120	300	275	250	225	200	175
96	240	220	200	180	160	140
72	180	165	150	135	120	105
48	120	110	100	90	80	70

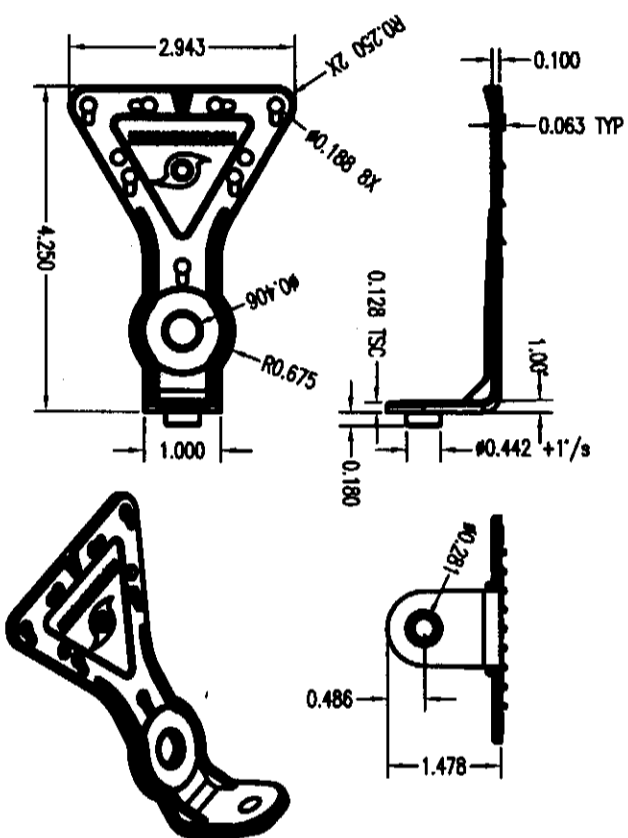

TOP MOUNTING CLIP DETAILS
INSIDE OR OUTSIDE MOUNT INSTALLATION - N.T.S.

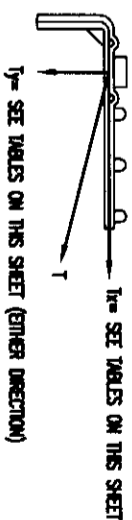

JOHN W. KAMPFMAN, JR., PE
FL License # 47516
DATE: 2-24-12

2010 FBC (NON-HIGH VELOCITY HURRICANE ZONE)

CA #6782
WWW.MEAENGINEERS.COM

2/12

ASTRO GUARD
Wind Abatement System

HURRICANE FABRIC LLC
PO BOX 80153
CLAYTON, MO 63108
PHONE: (238)688-0088
WWW.HURRICANEFABRIC.COM

REV. DESCRIPTION
1 xx/xx/xx-RESERVED

MEA
ENGINEERS, INC.
5656 Lawton Drive
Stennisville, Florida 34233
(841) 922-3834 CA-8072